

# Reversible Tapping Attachment

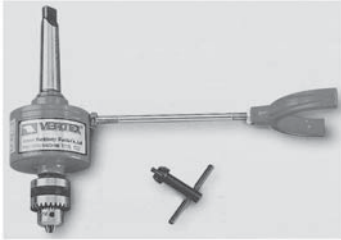

ORDER NO.	TAPPING CAPACITY	SHANK	TO WORK WITH DRILLING MACHINE	WEIGHT	PACKING mm	SPEED
K1 MT-2	φ 3-8mm	MT-2	DRILLING MACHINE, MUST BE EQUIPPED WITH MT-2 HOLE	1.8KG	90X90X240	1 : 1
K3 MT-3	φ 6-14mm	MT-3	OTHERS LIKE MT-3 SHANK BORING HOLE DRILLING MACHINE N.T. AVAILABLE	4.5KG	125X125X300	1 : 1
K4 MT-3	φ 12-25mm	MT-3	OTHERS LIKE MT-3 SHANK BORING HOLE DRILLING MACHINE N.T. AVAILABLE	6KG	160X160X360	1 : 1

K1-TYPE USED DRILL CHUCK TO FIX THE TAP  
 K3, K4 TYPE USED THE SLIDING PLATE OF THE SQUARE -  
 SHAPE HOLE TO FIX THE TAP

## ZOP-50 PRESET GAUGE

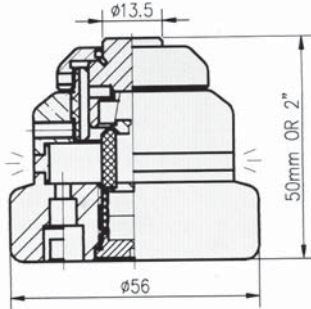

### ZOP - 50

- Height 50mm.
- With magnetic base.
- The red lamp will be lighted up when touched.
- Accuracy 0.005mm
- Combined vertical and horizontal in a unit.
- Weight: 0.5 kgs.

## MTI-ZOP-50

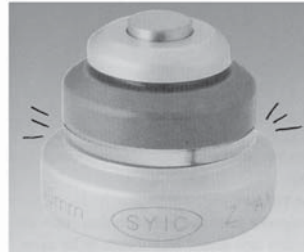

## Quill Kit

**Easy Installation**  
**Fits Most Vertical Knee Mills**

### FEATURES

- Easy to read LCD with resolution of .0005"/0.01mm.
- Push button controls for inch/mm, Zero-Set and On/Off.
- Powered by a single SR-44 Battery which lasts about 1 year with normal use.
- SPC Output for data transmission to Data Processors or LED Remote Display Box.

### SPECIFICATIONS

#### Quill Kit

Order No.	Description
053906	Digimatic Quill Kit complete with brackets & scale for Bridgeport Type machines.

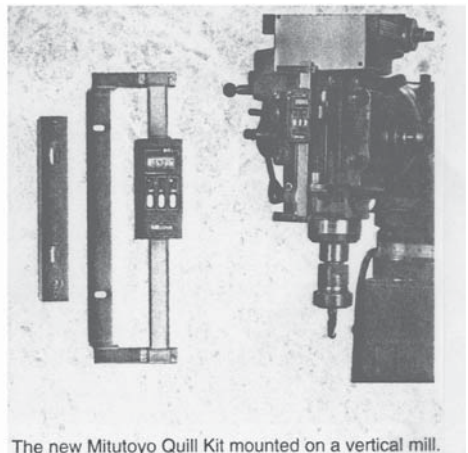

The new Mitutoyo Quill Kit mounted on a vertical mill.