

DUCOURRET

HIGH PRECISION LEVELS

Supplied in a wooden box

61 R INSPECTION BLOCK LEVELS

Stabilized cast iron. Flat and vee bearing surfaces. Surfaces lapped, hardened for length 140 - 200 - 300 mm. 2 adjustable vials (only 1 vial for type 100 mm length). To avoid the loss of accuracy caused by sealing and ageing of the sealing compound, the vial is unsealed. The vial can expand without stress if variations of temperature.

Maximum clarity of bubbles. Exceptional resistance to shock. Ease of replacement of the 2 vials. Same types of vials are used on 61R length 140, 200, 300, 500 mm and 67R.

| N° | Sensitivity | | | Accuracy of the base for 200 mm | |
|-----------|-------------|------------|------|---------------------------------|-------|
| | mm/m | in./10 in. | sec. | mm | in. |
| 61 R 0,05 | 0,05 | .0005 | 10 | 0,005 | .0002 |
| 61 R 0,02 | 0,02 | .0002 | 4 | 0,002 | .0001 |

| CODE | DESCRIPTION | SENSITIVITY |
|------------|-------------|-------------|
| 61R-140-02 | 140mm | .02 |
| 61R-140-05 | 140mm | .05 |
| 61R-200-02 | 200mm | .02 |
| 61R-200-05 | 200mm | .05 |
| 61R-300-02 | 300mm | .02 |
| 61R-300-05 | 300mm | .05 |

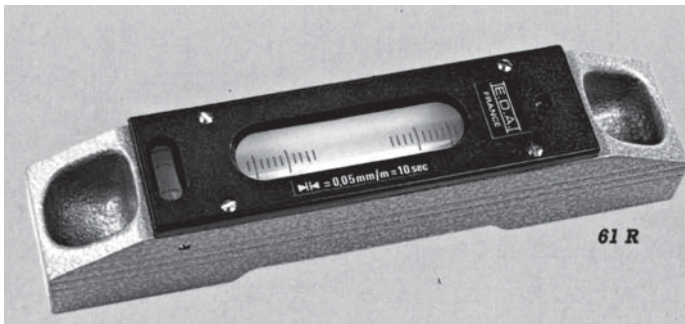
61 R

INSPECTION SQUARE BLOCK LEVELS

Supplied in a wooden box

67 R INSPECTION SQUARE BLOCK LEVELS

Stabilized cast iron. Two sides with flat bearing surfaces and two sides with flat and vee bearing surfaces. Same characteristics as 61 R. Insulating handles. Spare vials : the same as for 61 R. Dimensions : 200 x 200 x 40 mm - 300 x 300 x 40 mm.

| N° | Sensitivity | | | Accuracy of the base for 200 mm | |
|-----------|-------------|------------|------|---------------------------------|-------|
| | mm/m | in./10 in. | sec. | mm | in. |
| 67 R 0,05 | 0,05 | .0005 | 10 | 0,005 | .0002 |

| CODE | DESCRIPTION | SENSITIVITY |
|------------|-------------|-------------|
| 67R-200-05 | 200mm | .05 |
| 67R-300-05 | 300mm | .05 |

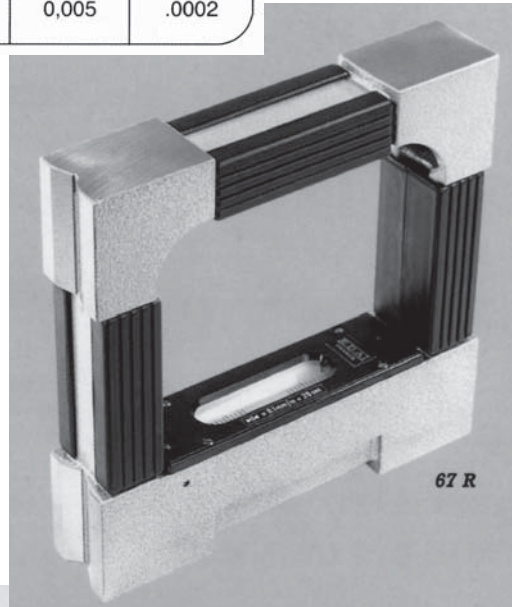

70 SMALL SQUARE BLOCK LEVELS

Sensitivity : 0,1 mm/m, 2 vials not adjustable.
Dimensions : 100 x 100 mm and 150 x 150 mm.
Magnetic base on request.

| CODE | DESCRIPTION | SENSITIVITY |
|------------|-------------|-------------|
| 70-100-100 | 100x100mm | .1mm/M |
| 70-150-150 | 150x150mm | .1mm/M |